

INSTALLATION, OPERATION AND MAINTENANCE INSTRUCTIONS, for the User and the Installer

Comfort

100 - 130 - 160 - 210 - 240



GENERAL RECOMMENDATIONS	4
PRODUCT INFORMATION	5
Energy labelling	5
Rating Plate	6
APPLIANCE DESCRIPTION.....	7
Models - Comfort 100 - 130 - 160 - 210 - 240.....	7
TECHNICAL CHARACTERISTICS	8
Dimensions and Main Characteristics	8
Performance	10
INSTALLATION.....	11
Safety Instructions.....	11
Packing Contents.....	13
Tools.....	13
Connection	13
Tank Installation : COMFORT 100 - 130 - 160 -210 - 240.....	14
Available Kits and Accessories	15
G3 Requirements and Guidance (UK).....	16
Hydraulic Connections.....	20

STARTING UP.....23

Safety Instructions to Fill the Tank.....23

Filling24

Checks before Starting up.....26

Starting Up procedure26

MAINTENANCE27

Periodic Checks by the User27

Annual Maintenance27

Draining.....28

Bringing back into Service after Maintenance.....28

NOTES

This manual contains important information with respect to the installation, the starting up and the maintenance of the appliance.

This manual must be provided to the user, who will read it carefully and keep it in a safe place.

We accept no liability should any damage result from the failure to comply with the instructions contained in this technical manual.



Essential recommendations for safety

- It is strictly prohibited to carry out any modifications to the appliance without the manufacturer's prior and written agreement.
- The product must be installed by a qualified engineer, in accordance with applicable local standards and regulations.
- The installation must comply with the instructions contained in this manual and with the standards and regulations applicable to domestic hot water tanks.
- Failure to comply with the instructions in this manual could result in personal injury or a risk of environmental pollution.
- The manufacturer declines all liability for any damage caused as a result of incorrect installation or in the event of the use of appliances or accessories that are not specified by the manufacturer.



Essential recommendations for the correct operation of the appliance

- In case of anomaly, please call your installer for advice.
- Faulty parts may only be replaced by genuine parts.
- Our water heaters are designed and manufactured for the exclusive purpose of heating and storing domestic hot water.
- The domestic hot water heaters must only be heated using hot water in a closed circuit.



General remarks

- The availability of certain models as well as their accessories may vary according to markets.
- The manufacturer reserves the right to change the technical characteristics and features of its products without prior notice. Please check for an updated version of this manual on the website www.acv.com.
- The part number (P/N) and serial number (S/N) of the appliance are indicated on its rating plate and must be provided to ACV in case of warranty claim. Failure to do so will make the claim void.
- In spite of the strict quality standards that ACV applies to its appliances during production, inspection and transport, faults may occur. Please immediately notify your approved installer of any faults.

ENERGY LABELLING

PRODUCT FICHE

ACV International
 Oude Vijverweg 6
 B-1653 Dworp
 Belgium



Product Model
 Comfort 100
 Comfort 130
 Comfort 160
 Comfort 210
 Comfort 240



General purpose hot water storage tank



	Comfort				
	100	130	160	210	240
Energy efficiency class	C	C	C	C	C
Standing Loss *	56 W	62 W	69 W	75 W	78 W
Hot water storage volume	105L	130L	161L	203L	242L

* According to EN12897:2006

RATING PLATE

	<small>Oude Vijverweg 6, 1655 Dworp BELGIUM www.acv.com</small>	Type : Comfort 160	
		P/N : A1002047	Year: 2015
		S/N : A001500	

Standard: EN 12897:2006			
Sanitary Operating Pressure	8,6 bar		
Primary Operating Pressure	3 bar		
Maximum Design Pressure	10 bar		
Primary Heating Power Input	32 kW		
Primary Flow Rate	0,70 l/s		
Actual Capacity	126 l		
Standing Heat Loss	0,91 kWh/24h		
Maximum Temperature	90 °C		
Rated Voltage			
			
<small>(21) 00000 (91) 00000000 (92) 9999</small>			

MODELS - Comfort 100 - 130 - 160 - 210 - 240

"Comfort" is a floor-standing hot water storage tank that operates within a heating system. It is based on the ACV tank-in-tank design. This tank can also be installed vertically on a wall, using an optional mounting support.

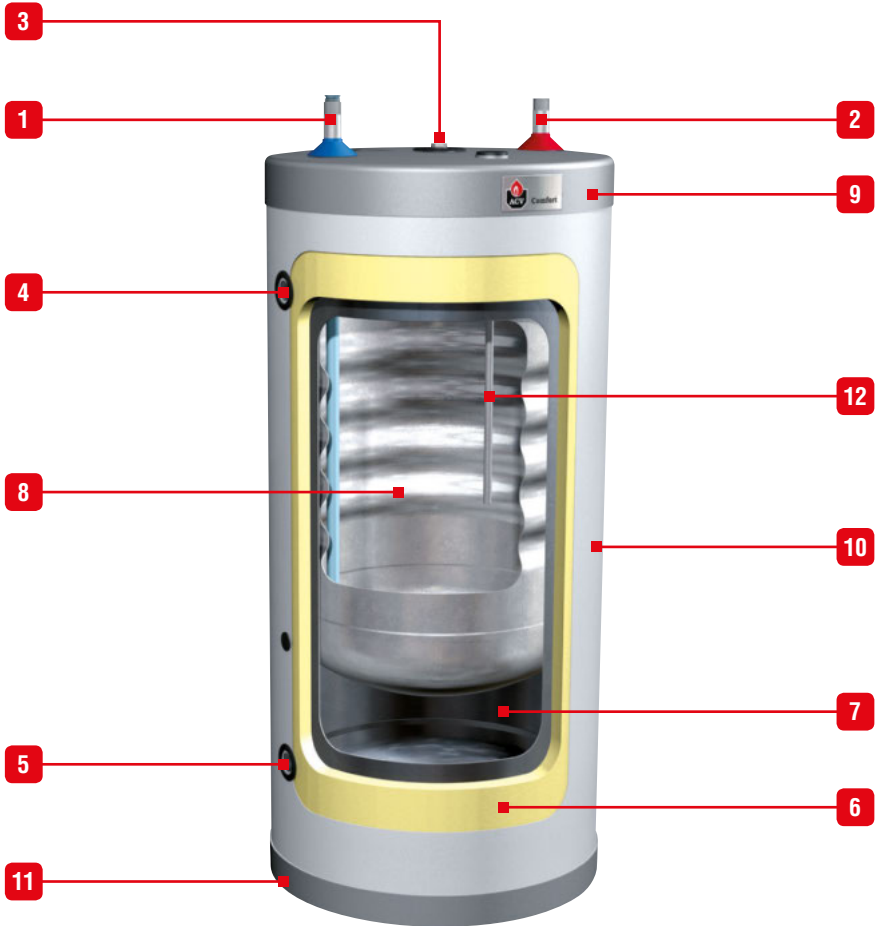

Key

- | | |
|--|--|
| <ul style="list-style-type: none"> 1. Cold water inlet 2. Domestic hot water outlet 3. Manual air vent valve 4. Primary fluid inlet 5. Primary fluid outlet 6. 30 mm of insulation in polyurethane 7. Primary carbon steel tank | <ul style="list-style-type: none"> 8. DHW stainless steel tank 9. Rigid polypropylene cover 10. External polypropylene casing 11. Rigid polypropylene base 12. Stainless steel dry-well |
|--|--|

DIMENSIONS AND MAIN CHARACTERISTICS

		Comfort				
Tank dimensions		100	130	160	210	240
A	mm	845	1005	1205	1475	1720
B	mm	580	740	940	1210	1455
C	mm	215	215	215	215	210
Empty weight	Kg	37	40	47	58	65

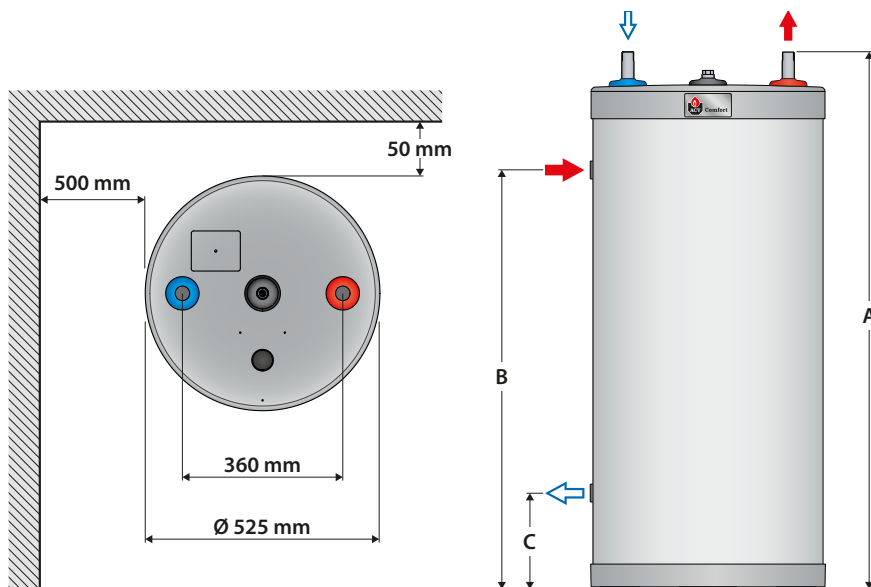

POSITION

The hot water tank must be installed in an area that is dry and protected from the elements. Choose the most suitable location according to the position of the boiler and distance to the domestic hot water supply, in order to reduce temperature and pressure drops within the pipe work.



The unit should be positioned to allow the replacement, if required, of the dip tube and dry well during servicing.

The unit can be floor standing or wall mounted (using correct mounting kit available as an option).

Main characteristics		Comfort				
		100	130	160	210	240
Total capacity	L	105	130	161	203	242
Primary capacity	L	30	55	62	77	78
DHW capacity	L	75	75	99	126	164
Primary connection [F]	"	1	1	1	1	1
DHW connection [M]	"	3/4	3/4	3/4	3/4	3/4
Primary pressure drop*	mbar	19.6	22.4	23.5	40.6	46.5
Heating surface area	m ²	1.03	1.03	1.26	1.54	1.94
Max Design Pressure*	bar	10	10	10	10	10
Reheat Performance - Primary Heating Power Input*	kW	18.4	18.4	24.7	32.2	39.2
Primary flow rate (to achieve Reheat Performance) *	L/sec.	0.7	0.7	0.7	1.25	1.25
Reheat time*	min	10	10	10	9	9
Standing Heat Loss*	kWh/24h	1.34	1.49	1.66	1.80	1.87
	W	56	62	69	75	78

* According to EN12897:2006

Maximum Operating Conditions		Comfort				
		100	130	160	210	240
Max. operating pressure - primary	bar	3	3	3	3	3
Max. operating pressure - DHW	bar	8.6	8.6	8.6	8.6	8.6
Supply pressure (DHW circuit)	bar	6	6	6	6	6
Maximum temperature - heating side	°C	90	90	90	90	90
Maximum temperature - DHW side	°C	80	80	80	80	80

Water quality

- Chlorides < 150 mg/L
- 6 ≤ pH ≤ 8
- If hardness > 20°FH, water softener recommended.

PERFORMANCE

DHW performance*		Comfort				
		100	130	160	210	240
Peak flow at 45 °C	L/10'	182	202	275	348	469
Peak flow at 60 °C	L/10'	105	117	161	209	272
Peak flow 1st hour at 45 °C	L/60'	604	672	911	1156	1560
Peak flow 1st hour at 60 °C	L/60'	345	384	549	689	913
Constant flow at 45 °C	L/h	507	564	763	970	1309
Constant flow at 60 °C	L/h	288	320	465	576	769

* Conditions: Primary circuit temp.: 85°C - ΔT : 10°C - Water supply temp.: 10°C

SAFETY INSTRUCTIONS



General remarks

- Connections (electrical, hydraulic) must be carried out in accordance with applicable standards and regulations.
- If the water drawing off point is far from the tank, installing an auxiliary DHW loop can allow to get hot water more quickly at all times.



Essential instructions for the correct operation of the system

- The tank must be installed in a dry and protected area.
- Install the appliance to ensure easy access at all times.
- To avoid any risk of corrosion, connect the stainless steel tank directly to the earth. Use an adjustable earth clamp (see example below) on one of the DHW connections to connect to the earth. Advised copper wire section: 2.5mm².



- Make sure to install a pressure reducing valve set at 4.5 bar in the DHW circuit if the supply pressure is higher than 6 bar.
- On the DHW circuit, install an approved safety group, comprised of a safety valve set at 7 bar, a check valve and a stop valve.
- Make sure that the outlet of the safety unit goes directly to the sewer to avoid any potential damage.
- Do not install the safety group above the tank to avoid water discharge on to the tank.
- The installation of a domestic expansion vessel avoids discharge from the safety valve (loss of water).
- Capacity of domestic water vessels:
 - 5 Litres: for models 100- 130
 - 8 Litres: for models 160 - 210
 - 12 Litres: for model 240



Refer to the manufacturer's technical instructions on the expansion vessel for more details.



Essential instructions for the safety of persons and the environment

- **Hot water can burn!**
In the event of small amounts of hot water repeatedly being drawn off, a stratification effect can develop in the tank. The upper hot water layer may then reach very high temperatures.
- ACV recommends using a pre-set thermostatic mixing valve in order to provide hot water at a maximum of 60°C.
- Water heated to wash clothes, dishes and for other uses can cause serious burns.
- In order to avoid exposure to extremely hot water that can cause serious burns, never leave children, old people, disabled or handicapped people in the bath or shower alone.
- Never allow young children to turn on the hot water or fill their own bath.
- Adjust the water temperature in accordance with usage and plumbing regulations.
- The risk of developing bacteria exists, including "Legionella pneumophila", if a minimum temperature of 60°C is not maintained in both the DHW tank and the hot water distribution network.



Essential instructions for the electrical safety

- Only an approved installer is authorized to carry out the electrical connections.
- Make sure that the appliance is connected to the earth.
- Install a 2-way switch and a fuse or circuit breaker of the recommended rating outside the appliance, so as to be able to shut power down when servicing the appliance or before performing any operation on it.
- Shut down external electrical supply of the appliance before performing any operation on the electrical circuit.
- This appliance is not intended for use by persons (including children) with reduced physical, sensory or mental capabilities, or lack of experience and knowledge, unless supervised or unless they have been given instruction concerning the use of the appliance by a person responsible for their safety.

PACKING CONTENTS

All appliances are delivered, tested and packaged separately.

Package

- One Comfort hot water tank.
- Multilingual Installation, Operation and Maintenance Instructions.
- One Energy label

TOOLS

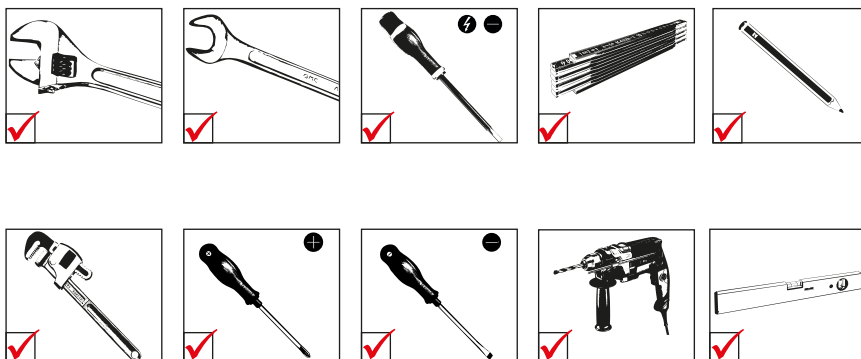

TANK INSTALLATION : COMFORT 100 - 130 - 160 -210 - 240

Floor mounting

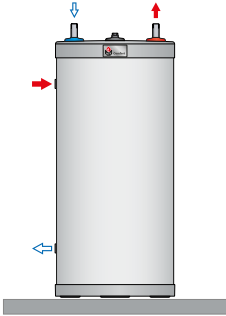

Vertical wall hung position : domestic water connections at the bottom side

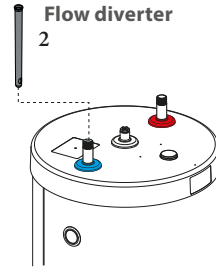
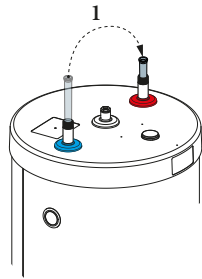
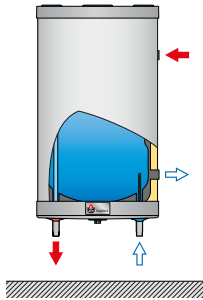

Horizontal wall hung position : domestic water connections on the right side



ACV does not recommend the installation in a horizontal position, as it will increase heat-up time and reduce DHW performances.

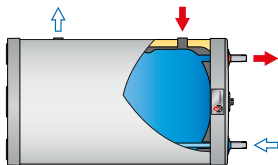

CH flow rate > 2000 l/h

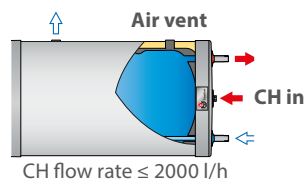

CH flow rate ≤ 2000 l/h

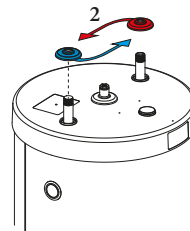
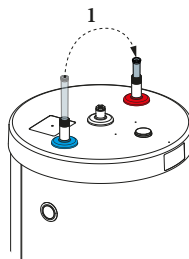
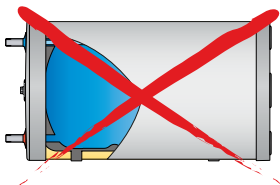

POSITION OF DHW SENSOR

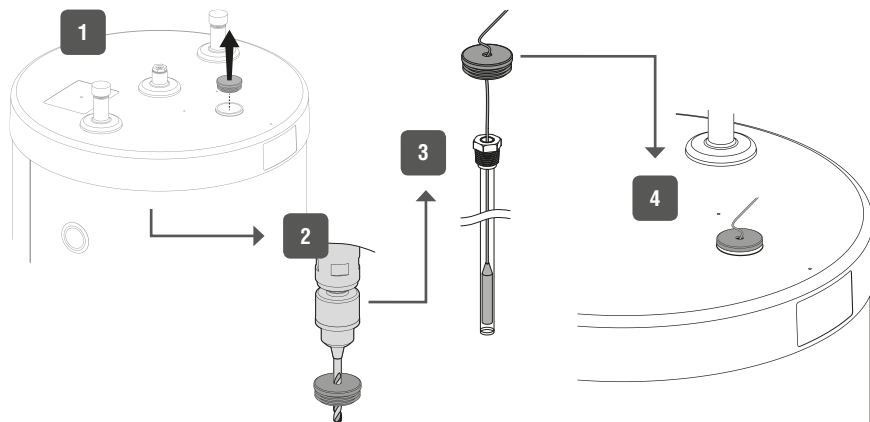

AVAILABLE KITS AND ACCESSORIES

DHW connection kit (code: 10800102)

- A. DHW temperature control valve
- B. Mixed domestic hot water outlet
- C. Cold water supply
- D. Drainage connection
- E. DHW expansion vessel connection
- S. Safety valve (10 bar)
- TH. Tank hot water outlet
- TC. Tank cold water inlet

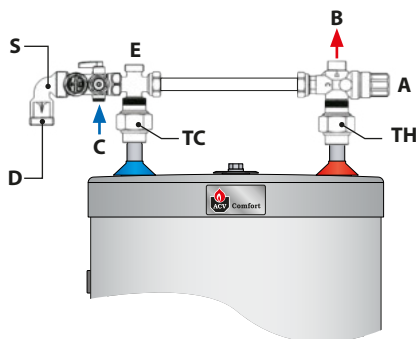

Thermostat control kit (60-80°) (code: A1002275)

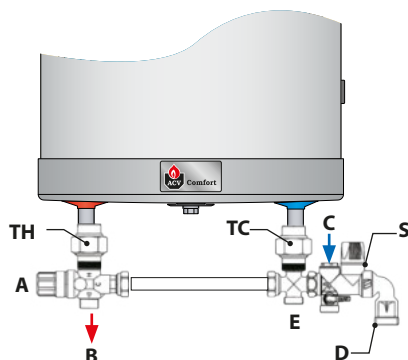
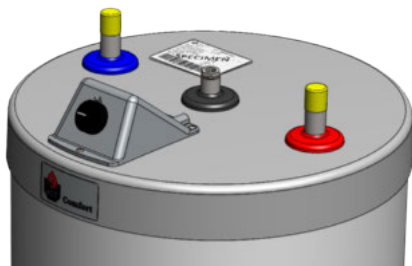

G3 REQUIREMENTS AND GUIDANCE

UK

Discharge pipe from safety valves

The *Building Regulation G3* requires that any discharge from an unvented system is conveyed to where it is visible, but will not cause danger to persons in or about the building.

The tundish and discharge pipes should be fitted in accordance with the requirements and guidance notes of Building Regulation G3. The G3 Requirements and Guidance sections 3.50 - 3.63 are detailed below.

For discharge pipe arrangements not covered by G3 Guidance advice should be sought from your local Building Control Officer.

Main characteristics :

- Any discharge pipe connected to the pressure relief devices (Expansion Valve and Temperature/Pressure Relief Valve) must be installed in a continuously downward direction and in a frost free environment.
- Water may drip from the discharge pipe of the pressure relief device.
- This pipe must be left open to the atmosphere.
- The pressure relief device is to be operated regularly to remove lime deposits and to verify that it is not blocked.

A typical discharge pipe arrangement is shown on next page.



General remarks

- **Discharge pipe-work D2 can now be a plastic pipe but only pipes that have been tested to a minimum 110°C must be used.**
- **Discharge pipe D2 can now be plumbed into the soil stack but only soil stacks that can handle temperatures of 99°C or greater should be used.**

Extract from “The Building Regulation G3” :

Discharge pipe D1

- 3.50 *Safety devices such as temperature relief valves or combined temperature and pressure and pressure relief valves (see paragraphs 3.13 or 3.18) should discharge either directly or by way of a manifold via a short length of metal pipe (D1) to a tundish.*
- 3.51 *The diameter of discharge pipe (D1) should be not less than the nominal outlet size of the temperature relief valve.*
- 3.52 *Where a manifold is used it should be sized to accept and discharge the total discharge from the discharge pipes connected to it.*
- 3.53 *Where valves other than the temperature and pressure relief valve from a single unvented hot water system discharge by way of the same manifold that is used by the safety devices, the manifold should be factory fitted as part of the hot water storage system unit or package.*

Tundish

- 3.54 *The tundish should be vertical, located in the same space as the unvented hot water storage system and be fitted as close as possible to, and lower than, the valve, with no more than 600mm of pipe between the valve outlet and the tundish.*

Note: *To comply with the Water Supply (Water Fittings) Regulations, the tundish should incorporate a suitable air gap.*

UK

- 3.55 *Any discharge should be visible at the tundish. In addition, where discharges from safety devices may not be apparent, e.g. in dwellings occupied by people with impaired vision or mobility, consideration should be given to the installation of a suitable safety device to warn when discharge takes place, e.g. electronically operated.*

Discharge pipe D2

- 3.56 *The discharge pipe (D2) from the tundish should:*
 (a) *have a vertical section of pipe at least 300mm long below the tundish before any elbows or bends in the pipework; and*
 (b) *be installed with a continuous fall thereafter of at least 1 in 200.*
- 3.57 *The discharge pipe (D2) should be made of:*
 (a) *metal; or*
 (b) *other material that has been demonstrated to be capable of safely withstanding temperatures of the water discharged and is clearly and permanently marked to identify the product and performance standard (e.g. as specified in the relevant part of BS 7291)*
- 3.58 *The discharge pipe (D2) should be at least one pipe size larger than the nominal outlet size of the safety device unless its total equivalent hydraulic resistance exceeds that of a straight pipe 9m long, i.e. for discharge pipes between 9m and 18m the equivalent resistance length should be at least two sizes larger than the nominal outlet size of the safety device; between 18 and 27m at least 3 sizes larger, and so on; bends must be taken into account in calculating the flow resistance. See figure, table and the worked example.*
- 3.59 *Where a single common discharge pipe serves more than one system, it should be at least one pipe size larger than the largest individual discharge pipe (D2) to be connected.*
- 3.60 *The discharge pipe should not be connected to a soil discharge stack unless it can be demonstrated that the soil discharge stack is capable of safely withstanding temperatures of the water discharged, in which case, it should:*
 (a) *contain a mechanical seal, not incorporating a water trap, which allows water into the branch pipe without allowing foul air from the drain to be ventilated through the tundish;*
 (b) *be a separate branch pipe with no sanitary appliances connected to it;*
 (c) *if plastic pipes are used as branch pipes carrying discharge from a safety device they should be either polybutylene (PB) to Class S of BS 7291-2:2006 or cross linked polyethylene (PE-X) to Class S of BS 7291-3:2006; and (d) be continuously marked with a warning that no sanitary appliances should be connected to the pipe.*

Note:

1. *Plastic pipes should be joined and assembled with fittings appropriate to the circumstances in which they are used as set out in BS EN ISO 1043-1.*
2. *Where pipes cannot be connected to the stack it may be possible to route a dedicated pipe alongside or in close proximity to the discharge stack.*

Termination of discharge pipe

- 3.61 *The discharge pipe (D2) from the tundish should terminate in a safe place where there is no risk to persons in the vicinity of the discharge.*
- 3.62 *Examples of acceptable discharge arrangements are:*
 (b) *to a trapped gully with the end of the pipe below a fixed grating and above the water seal;*
 (c) *downward discharges at low level; i.e. up to 100mm above external surfaces such as car parks, hard standings, grassed areas etc. are acceptable providing that a wire cage or similar guard is positioned to prevent contact, whilst maintaining visibility; and*
 (d) *discharges at high level: e.g. into a metal hopper and metal downpipe with the end of the discharge pipe clearly visible or onto a roof capable of withstanding high temperature discharges of water and 3m from any plastic guttering system that would collect such discharges.*

3.63 The discharge would consist of high temperature water and steam. Asphalt, roofing felt and non-metallic rainwater goods may be damaged by such discharges.

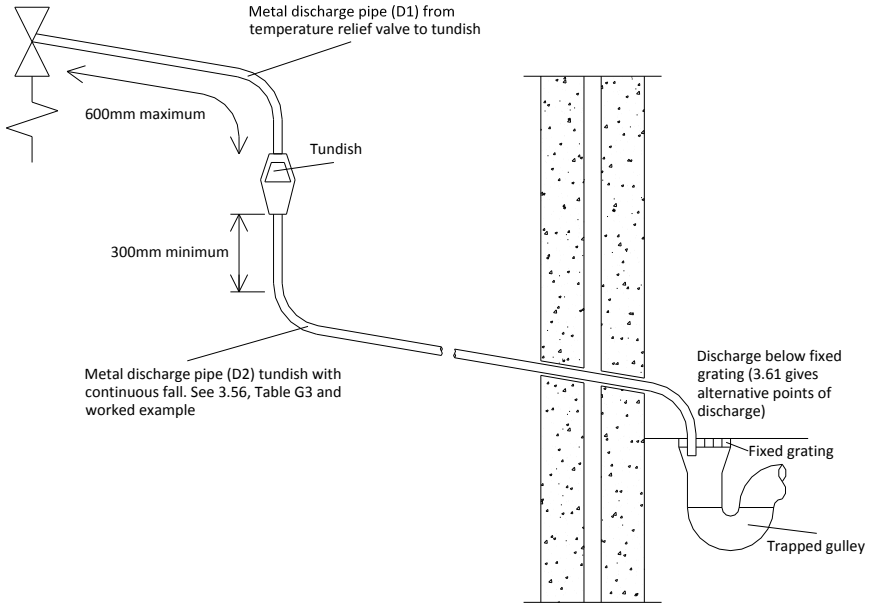

Figure G3: Typical discharge pipe arrangement

Table G3 – Sizing of copper discharge pipe 'D2' for common temperature relief valve outlet sizes

Valve outlet size	Minimum size of discharge pipe D1	Minimum size of discharge pipe D2 from tundish	Maximum resistance allowed, expressed as a length of straight pipe (i.e. no elbows or bends)	Resistance created by each elbow or bend.
G½	15mm	22mm	Up to 9m	0.8m
		28mm	Up to 8m	1.0m
		35mm	Up to 27m	1.4m
G¾	22mm	28mm	Up to 9m	1.0m
		35mm	Up to 8m	1.4m
		42mm	Up to 27m	1.7m
G1	28mm	35mm	Up to 9m	1.4m
		42mm	Up to 8m	1.7m
		54mm	Up to 27m	2.3m



Worked example of discharge pipe sizing

Figure on the left shows a G1/2 temperature relief valve with a discharge pipe (D2) having 4 No. elbows and length of 7m from the tundish to the point of discharge.

From Table:

Maximum resistance allowed for a straight length of 22mm copper discharge pipe (D2) from a G1/2 temperature relief valve is 9.0m.

- *Subtract the resistance for 4 No. 22mm elbows at 0.8m each = 3.2m*
- *Therefore the permitted length equates to: 5.8m*
- *5.8m is less than the actual length of 7m therefore calculates the next largest size.*

Maximum resistance allowed for a straight length of 28mm pipe (D2) from a G1/2 temperature relief valves equates to 18m.

- *Subtract the resistance of 4 No. 28mm elbows at 1.0m each = 4.0m*
- *Therefore the maximum permitted length equates to: 14m*
- *As the actual length is 7m, a 28mm (D2) copper pipe will be satisfactory.*



Essential recommendations for safety

- **The temperature/pressure relief valve should only be replaced by a competent person.**
- **No control or safety valves should be tampered with or used for any other purpose.**
- **The discharge pipe should not be blocked or used for any other purpose.**
- **The tundish should not be located adjacent to any electrical components**

CONNECTION



Essential instructions for the safety of persons and the environment

- Refer to the safety instructions for the installation. Failure to comply with these instructions can result in damages to the system, severe injuries or death.
- Hot water can burn! ACV recommends using a pre-set thermostatic mixing valve in order to provide hot water at a maximum of 60°C.



Essential instructions for the correct operation of the system

- The filling circuit of the DHW tank must be equipped with a safety group, comprised at least of a stop valve, a check valve, a safety valve set at 7 bar, and possibly, an expansion vessel of the appropriate size. Make sure that the circuit between the tank and the safety valve is always open.
- The third DHW tank connection, if any, can be used for the auxiliary DHW loop. If the connection is not used, replace the protective plug by a brass plug of the appropriate size.



General remarks

- In certain countries the domestic kits must be approved.
- The circuit illustrations are basic principle diagrams only.

CONNECTION TO THE DHW CIRCUIT (Typical wall installation)

Key

1. Filling valve
2. Pressure reducing valve (set at 4.5 bar)
3. Check valve
4. Stop valve
5. DHW expansion vessel
6. Pressure gauge
7. Safety valve (set at 7 bar)
8. Drain valve
9. Grounding
10. Stop valve
11. Thermostatic mixing valve
12. Hot water outlet

— — — — — Cold water
 ————— Hot water

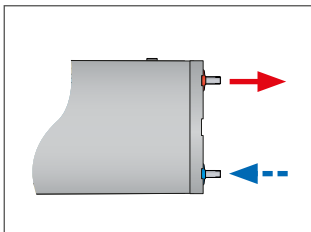

Horizontal installation

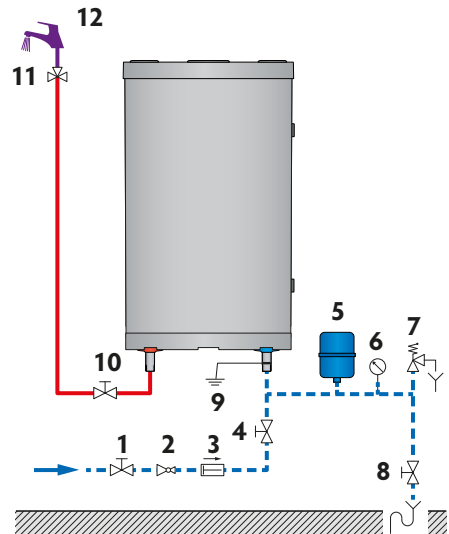

Vertical installation

CONNECTION TO THE DHW CIRCUIT (Typical floor installation)

Key

- 1. Filling valve
- 2. Pressure reducing valve (set at 4.5 bar)
- 3. Check valve
- 4. Expansion vessel
- 5. Safety valve (set at 7 bar)
- 6. Drain valve
- 7. Hot water outlet
- 8. Pressure gauge
- 9. Grounding
- 10. Stop valve
- 11. Thermostatic mixing valve

— Cold water
— Hot water

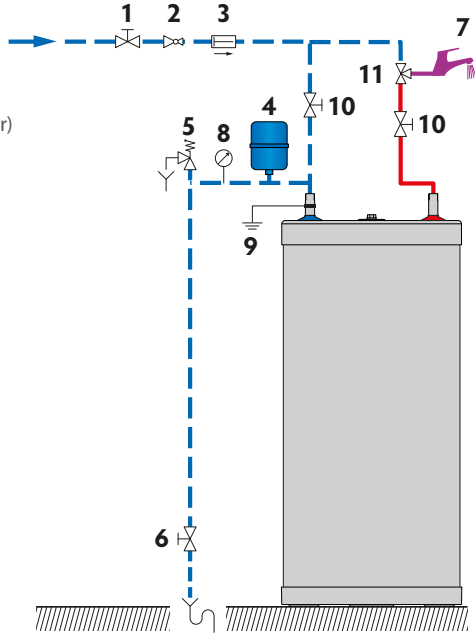

CONNECTION TO THE PRIMARY CIRCUIT (Typical floor installation)

Key

- 1. Primary circuit filling valve
- 2. Charging pump
- 3. Check valve
- 4. Primary circuit stop valve
- 5. Expansion vessel
- 6. Pressure gauge
- 7. Safety valve
- 8. Drain valve
- 9. Stop valve

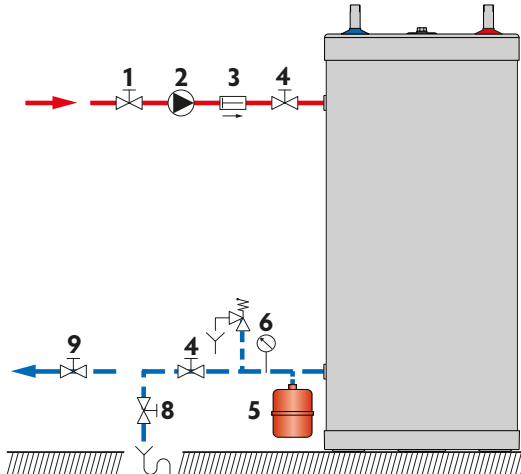

CONNECTION TO THE PRIMARY CIRCUIT (Typical wall installation)

Key

1. Primary circuit filling valve
2. Charging pump
3. Check valve
4. Primary circuit stop valve
5. Expansion vessel
6. Pressure gauge
7. Safety valve
8. Drain valve
9. Stop valve

— Cold water
— Hot water

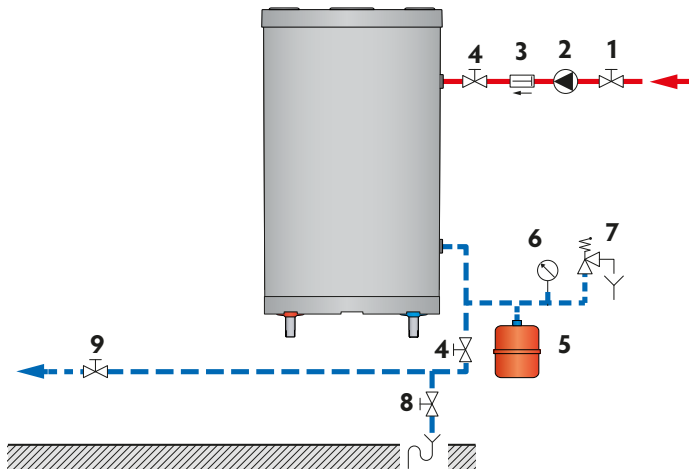

Vertical installation

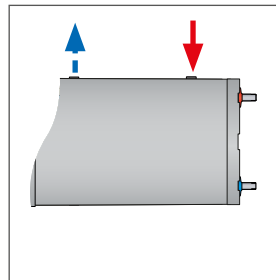

Horizontal installation

SAFETY INSTRUCTIONS TO FILL THE TANK



Essential instructions for the safety of persons and the environment

- The DHW tank must always be filled and pressurised before filling and pressurising the primary circuit.
- Do not use vehicle antifreeze. This can cause serious injury or death, or damage facilities.
- If antifreeze is needed in the primary circuit, it must comply with Public Hygiene Regulations and must be non-toxic. A food-grade Propylene Glycol is recommended. It must be diluted according to the ratio recommended in the local regulations.
- Consult the manufacturer to determine the compatibility of the antifreeze with the tank's construction materials.



Essential instructions for the correct operation of the system

- Before bringing the tank into service, check the connections to avoid any risk of leaks during filling.
- Only use drinking water to check that the DHW tank is watertight. The on-site test pressure must not exceed a pressure surge of 8,6 bar.
- Using antifreeze in the primary circuit will lead to a reduction in the heating performance. The higher the concentration of antifreeze in the circuit, the lower the performance.

FILLING



Essential instruction for the correct operation of the system

- The DHW tank must always be filled and pressurised before filling and pressurising the primary circuit.

FILLING THE DHW TANK (Figure 1)



General remark

- Connect the safety valve outlet to the sewer.
1. To fill the tank, open a hot water tap (2) located at the highest point of the system. It enables to bleed the air from the system.
 2. Open the filling valve (1) and the stop valves (3) to fill the DHW tank.
 3. Close the hot water tap (2), after the water flow has stabilised and the air has been completely evacuated.
 4. Check all the connections of the system for leaks.

FILLING THE PRIMARY CIRCUIT (Figure 2)



General remark

- If the tank is used within a heating system, refer to the heating boiler manual.
1. Check that the drain valve (3) of your primary circuit is tightly closed.
 2. Open the stop valves (1) and (2) of the primary circuit connected to the heating boiler.
 3. Open the air bleed valve (4) located on the top of the hot water tank.
 4. When the air is eliminated, close the air bleed valve (4). Make sure the air bleed valve is tight.

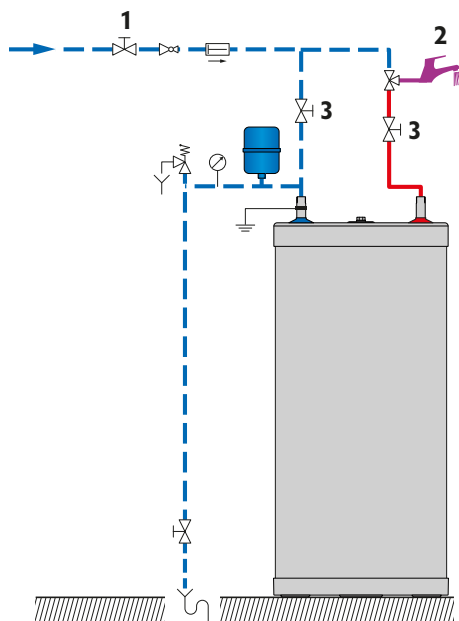

Figure 1

— Cold water
— Hot water

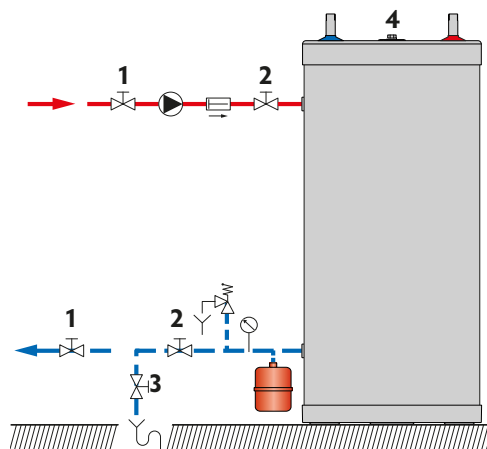
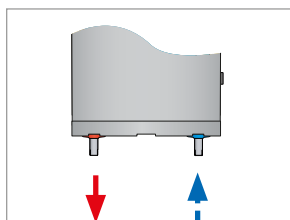
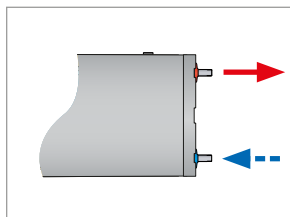

Figure 2



Vertical installation
on a wall



Horizontal installation
on a wall

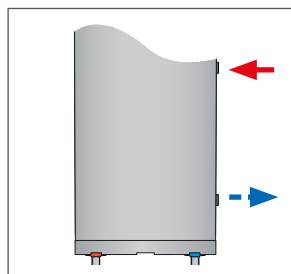

Vertical installation
on a wall

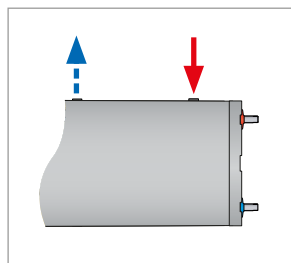

Horizontal installation
on a wall

CHECKS BEFORE STARTING UP

- Check that the safety valves (DHW and primary) are correctly installed and that the outlets are connected to the sewer.
- Check that the DHW tank and the primary circuit are filled with water.
- Check that the air has been correctly bled from both circuits.
- Check that the tank's upper air bleed valve is tight.
- Check that the water side and heat source side pipes are correctly connected and not leaking.

STARTING UP PROCEDURE



To put the heating system into service, refer to the heating boiler manual.

PERIODIC CHECKS BY THE USER

- Check the pressure of the primary circuit pressure gauge: it should be between 0.5 and 1.5 bar.
- Visually inspect, on a regular basis, the valves, connections and accessories in order to detect any leaks or malfunction.
- Periodically check the air bleed valve located on the tank top to ensure that it is not leaking.
- Check that the DHW water circuit safety valves are in good operating condition.
- In the event of a problem, please contact an engineer or your installer.

ANNUAL MAINTENANCE



Essential instructions for the correct operation of the appliance

- **The discharge pipe of the safety unit must be open to the outside. If the safety unit drips periodically, it may be due to an expansion problem or clogging of the valve.**
- **For internal inspections, the hand hole can be used. If there is none, use one of the water connections to insert the appropriate inspection equipment. If necessary, drain the tank before inspection.**

The annual maintenance service, performed by an engineer, must include:

- A check of the air bleed valve: the bleeding of air can lead to the need for adding water to the system.
- A check of the primary and DHW circuit pressure gauges.
- The manual activation of the storage water circuit safety valve once a year. This operation will lead to a discharge of hot water.
- A check of the correct operation of valves, taps, control units and accessories that are possibly installed [refer to the manufacturer's instructions if necessary].

DRAINING



Essential instruction for the safety of persons and the environment

- The water coming out of the drain valve is very hot and can cause very severe burns. Make sure the area around the hot water flow is clear of people.



Essential instruction for the electrical safety

- Shut down the external electrical supply of the appliance before draining.



Essential instructions for the correct operation of the system

- Drain the tank if it is not used in winter and is at risk from exposure to ice. If the primary circuit water contains antifreeze, only the DHW tank must be drained. If the heating circuit does not contain antifreeze, the heating circuit and domestic water must be drained.
- Before draining the DHW, isolate the tank and lower the pressure of the heating circuit to 1 bar, in order to prevent the DHW tank from being crushed.

DRAINING THE PRIMARY CIRCUIT (Figure 3)

To drain the primary circuit of the hot water heater:

1. Stop the charging pump.
2. Isolate the primary circuit by closing the stop valves (1).
3. Connect the drain valve (2) to the sewer using a flexible hose.
4. Open the drain valve (2) and drain the water from the primary circuit to the drain.
5. Open the tank's air bleed valve (3) to accelerate drainage.
6. Close the drain valve (2) and air bleed valve (3) after draining the tank.

DRAINING THE DHW TANK (Figure 4)

To drain the hot water heater's DHW tank:

1. Open fully the hot water tap (3) for at least 60 minutes to make sure the DHW tank has cooled down sufficiently.
2. Close the filling valve (1) and the stop valve (4).
3. Connect the drain valve (2) to the sewer using a flexible hose.
4. Open the drain valve (2) and drain the water from the DHW tank to the sewer.
5. To accelerate the tank's drainage, open a hot water tap located higher than the tank connection in the DHW circuit.
6. Close the drain valve (2) and the hot water tap (3) after having drained the DHW tank.

BRINGING BACK INTO SERVICE AFTER MAINTENANCE

Refer to "Starting Up procedure", page 26.

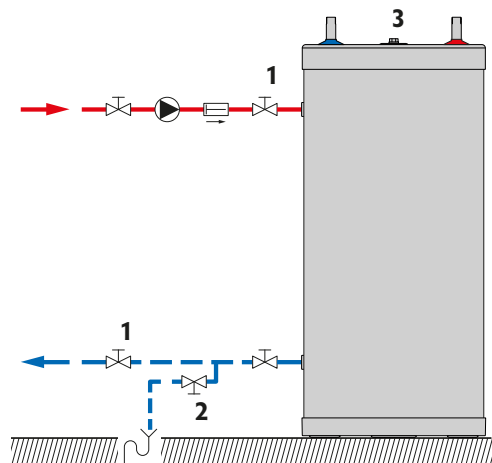
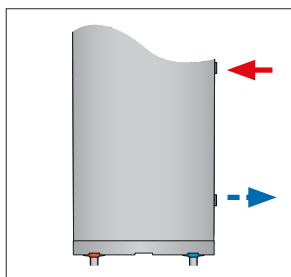
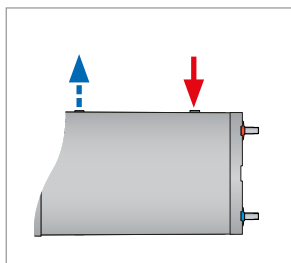

Figure 3

— Cold water
— Hot water



Vertical installation on a wall



Horizontal installation on a wall

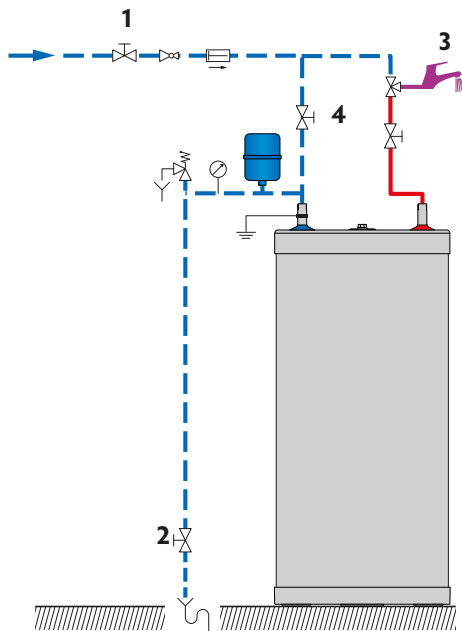
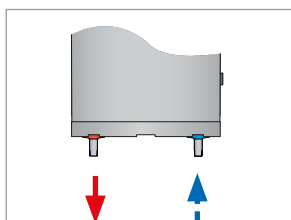
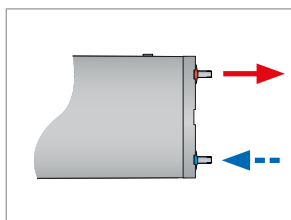

Figure 4



Vertical installation on a wall



Horizontal installation on a wall



A series of horizontal dotted lines for writing, starting from the top right of the notepad illustration and extending across the page.